

GRU A MONTAGGIO RAPIDO
 GRUE A MONTAGE RAPIDE
 GRUA DE RAPIDO MONTAJE
 GRUA DE MONTAGEM RAPIDA
 QUICK SELFERECTING CRANE
 HYDRAULISCHER SCHNELLMONTAGEKRAN

Curve di carico – Courbes de charges – Load diagrams – LastKurven – Curvas de cargas

	<table border="1" style="display: inline-table; margin-right: 10px;"> <tr><td>3</td><td>25</td><td>30,3</td></tr> <tr><td>800</td><td>800</td><td>800</td></tr> </table> m kg	3	25	30,3	800	800	800	OP	<table border="1" style="display: inline-table;"> <tr><td>3</td><td>25</td><td>30,3</td></tr> <tr><td>1000</td><td>1000</td><td>1000</td></tr> </table> m kg	3	25	30,3	1000	1000	1000			
3	25	30,3																
800	800	800																
3	25	30,3																
1000	1000	1000																
	<table border="1" style="display: inline-table;"> <tr><td>3</td><td>10.3</td><td>12</td><td>16</td><td>20</td><td>24</td><td>28</td><td>31</td></tr> <tr><td>4000</td><td>4000</td><td>3290</td><td>2290</td><td>1735</td><td>1380</td><td>1135</td><td>1000</td></tr> </table> m kg	3	10.3	12	16	20	24	28	31	4000	4000	3290	2290	1735	1380	1135	1000	
3	10.3	12	16	20	24	28	31											
4000	4000	3290	2290	1735	1380	1135	1000											
	<table border="1" style="display: inline-table;"> <tr><td>3</td><td></td><td>18.5</td><td>20</td><td>24</td><td>28</td><td>31</td></tr> <tr><td>2000</td><td></td><td>2000</td><td>1865</td><td>1500</td><td>1240</td><td>1100</td></tr> </table> m kg	3		18.5	20	24	28	31	2000		2000	1865	1500	1240	1100			
3		18.5	20	24	28	31												
2000		2000	1865	1500	1240	1100												
	<table border="1" style="display: inline-table;"> <tr><td>3</td><td>15.5</td><td>16</td><td>20</td><td>24</td><td>28</td><td>31</td></tr> <tr><td>2500</td><td>2500</td><td>2445</td><td>1865</td><td>1500</td><td>1240</td><td>1100</td></tr> </table> m kg	3	15.5	16	20	24	28	31	2500	2500	2445	1865	1500	1240	1100			
3	15.5	16	20	24	28	31												
2500	2500	2445	1865	1500	1240	1100												
	<table border="1" style="display: inline-table; margin-right: 10px;"> <tr><td>3</td><td>11.3</td><td>14.4</td></tr> <tr><td>4000</td><td>4000</td><td>3000</td></tr> </table> m kg	3	11.3	14.4	4000	4000	3000		<table border="1" style="display: inline-table; margin-right: 10px;"> <tr><td>3</td><td>14.4</td></tr> <tr><td>2000</td><td>2000</td></tr> </table> m kg	3	14.4	2000	2000	<table border="1" style="display: inline-table;"> <tr><td>3</td><td>14.4</td></tr> <tr><td>2500</td><td>2500</td></tr> </table> m kg	3	14.4	2500	2500
3	11.3	14.4																
4000	4000	3000																
3	14.4																	
2000	2000																	
3	14.4																	
2500	2500																	

Reazioni – Reactions – Réactions – Eckdrücke – Reacciones – Reações

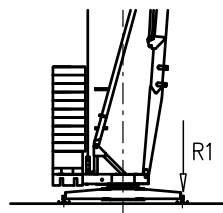

R1 ● 22 t ■ 15 t

▲ 12.7 t ○ 25.6 t

- N°2 A=3500Kg (1750Kgx2)
- N°2 B=2100Kg (1050Kgx2)
- N°16 C=20000Kg (1250Kgx16)

- Reazioni in servizio | Reactions in service | Réactions en service
Reaktionskräfte in betrieb | Reacciones en servicio | Em serviço
- Reazioni fuori servizio | Reactions out of service | Réactions hors service
Reaktionskräfte außer betrieb | Reacciones fuera de servicio | Fora de serviço
- ▲ Peso della gru senza assali | Dead weight without transport axles | Poids de construction sans essieux
Konstruktionsgewicht ohne transportachse | Peso de la grua sin tren de transporte | peso de la grua sem carro de transporte
- Peso zavorra rotante | Ballast weight | Poids du lest
Ballastgewicht | Peso de lastre | Peso de lastre rotativo

Montaggio – Montage – Erection – Montage – Montaje – Montagem

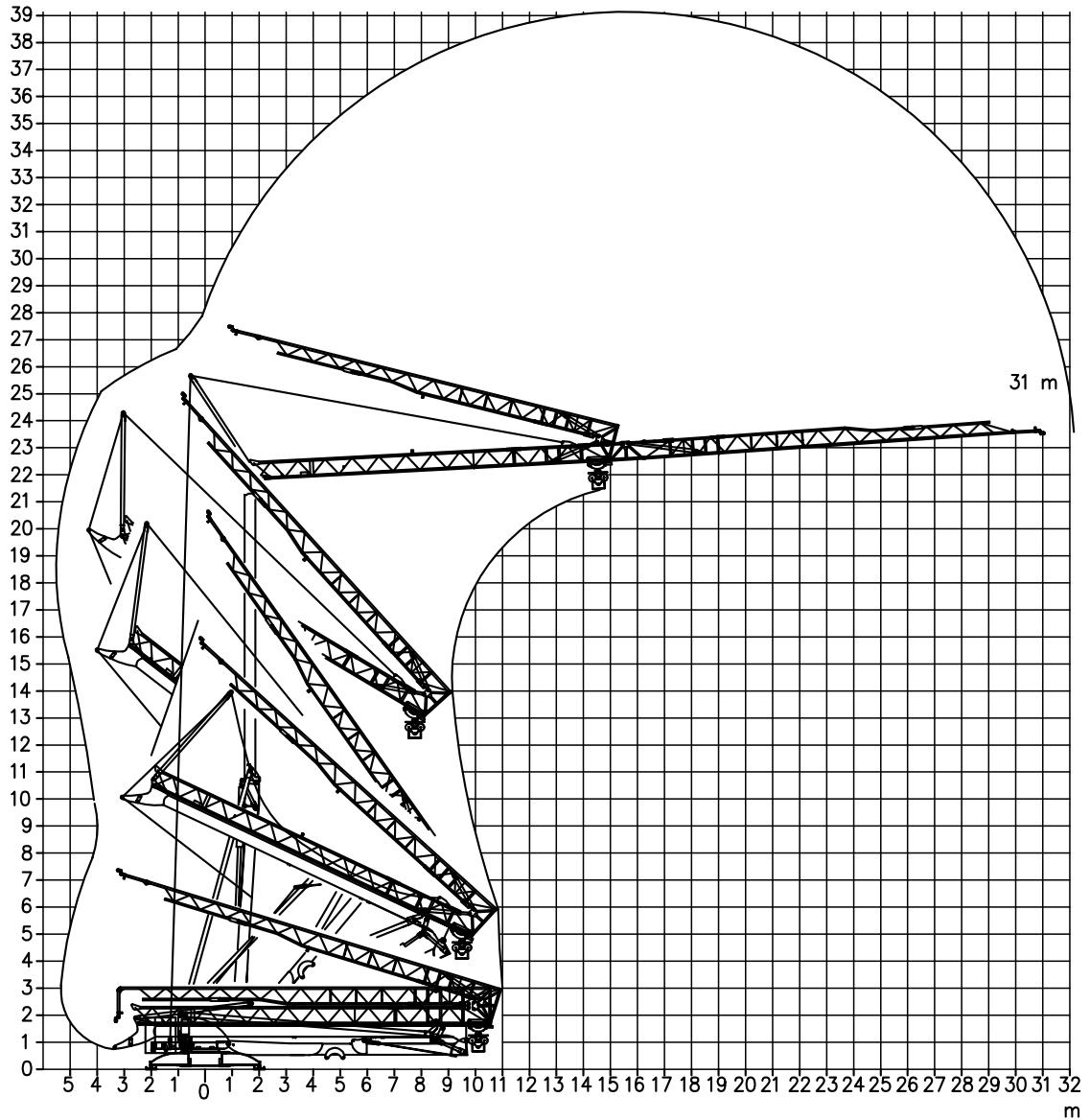

Trasporto – Transport – Transport – Transport – Transporte – Transporte

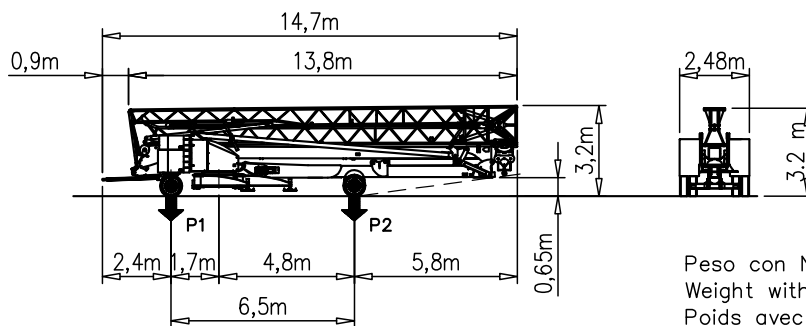

P1	Kg	9260
P2	Kg	9840
Ptot	Kg	19100

Peso con N°2 A+ N°2 B+ assali
 Weight with N°2 A+ N°2 B+ transport axles
 Poids avec N°2 A+ N°2 B+ essieux de transport
 Gewicht mit N°2 A+ N°2 B+ transportachsen
 Peso con N°2 A+ N°2 B+ ejes de transporte
 Peso com N°2 A+ N°2 B+ eixos de transporte

Meccanismi – Mechanisms – Mécanismes – Antriebe – Mecanismos

V12.40 Sollevamento Hoisting Levage Heben Elevaciòn Elevaçao	m/min						V12.40 8.8 kW (12 Hp) 18 kVA
		t	4	15	30		
	m/min						
		t	2	7.5	15		
V15.45 Sollevamento Hoisting Levage Heben Elevaciòn Elevaçao	m/min						V15.45 11 kW (15 Hp) 20 kVA
		t	4	15	30		
	m/min						
		t	2.5	2.5	2.0		

Carrello Trolleying Distribution Katzfahren Distribuciòn Distribuiçao			1a	0 → 45	m/min	2.2 kW / 3 kW
			2a			
			3a			
			1a	0 → 17	m/min	3 kW
			2a			
			3a			
		1a	0 → 17	m/min	3 kW	
		2a				
		3a				
Rotazione Slewing Orientation Schwenken Orientaciòn Rotaçao			1a	0 → 0.8	giri/min tr/min rp/min	2.2 kW
			2a			
			3a			
			3a			

	400V – 50 Hz
Potenza elettrica necessaria – Puissance électrique nécessaire Necessary electric power – Anschlusswert – Potencia eléctrica necesaria	V12.40 18 kVA V15.45 20 kVA
Conforme alla direttiva 2000/14/CE sul livello acustico Conforme à la directive 2000/14/CE sur le niveau acoustique In compliance with the 2000/14/CE instruction on noise level Germäss EWG-Richtlinie 2000/14/CE über Schall-Leistungspegel Conforme con la directiva 2000/14/CE sobre el nivel acustico	FEM 1.001–A3