

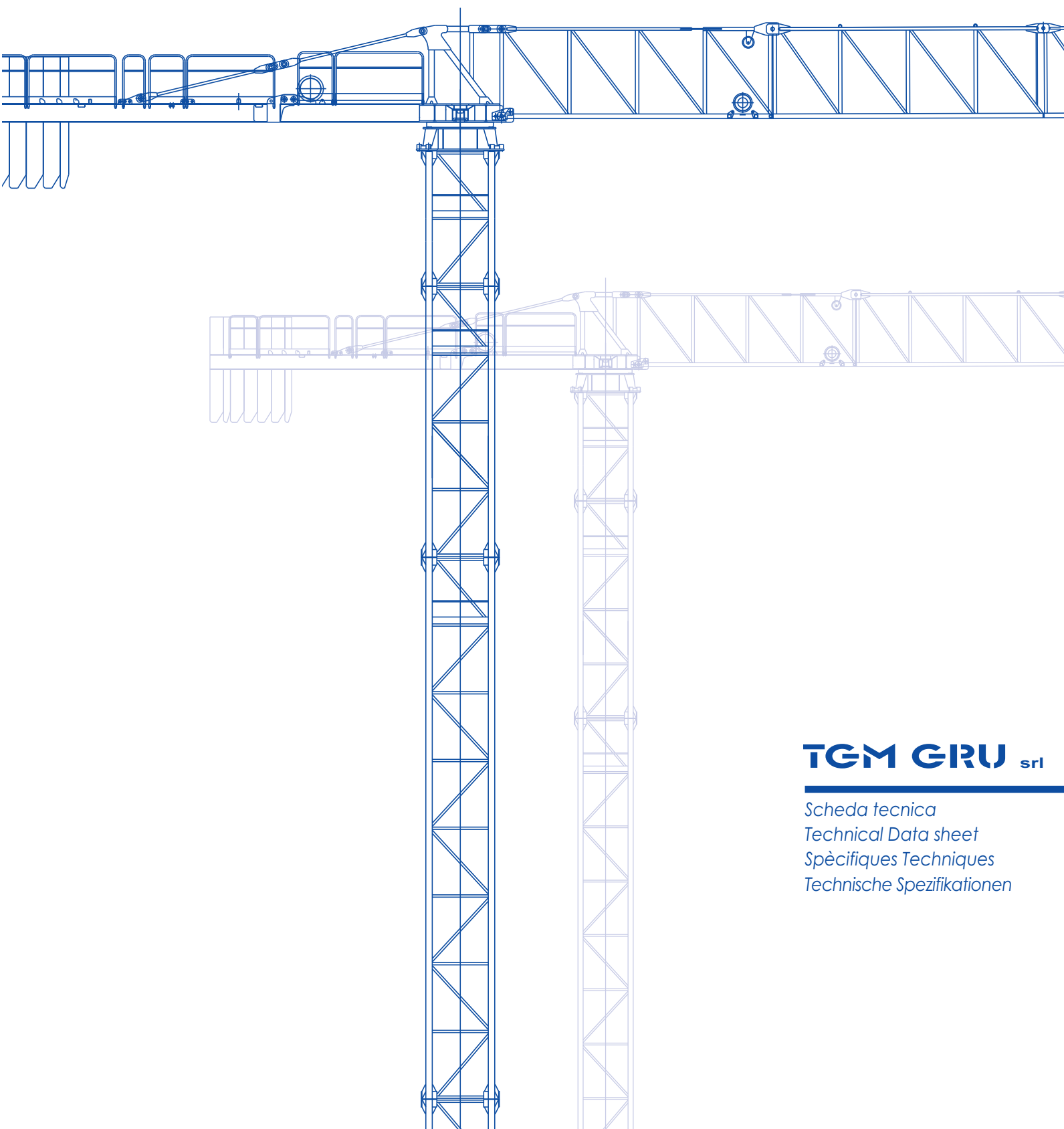

GRU A TORRE "TOPLESS"
"TOPLESS" CITY CRANE

GRT55



TGM GRU srl

*Scheda tecnica
Technical Data sheet
Spécifiques Techniques
Technische Spezifikationen*

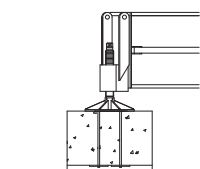
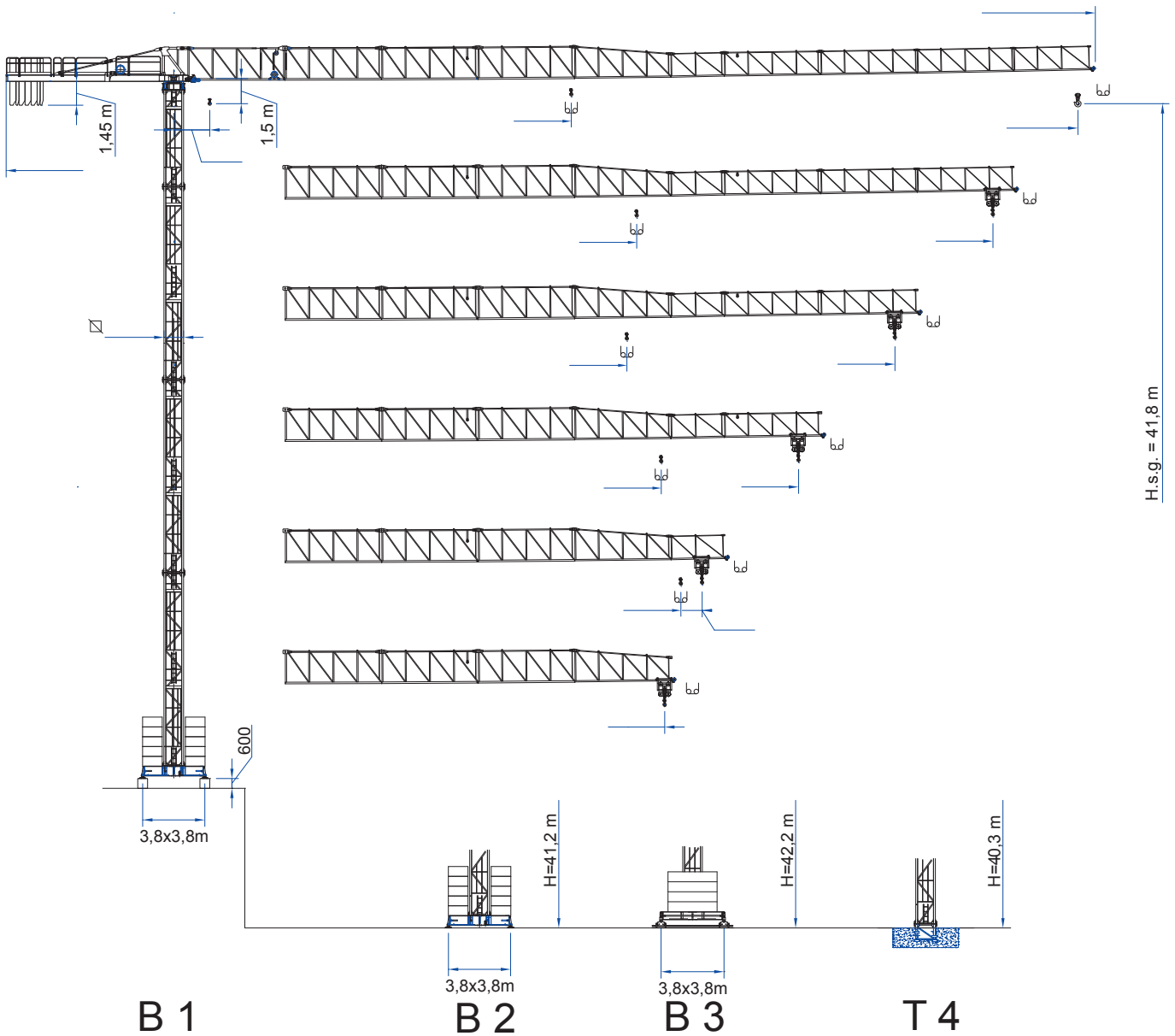

B 1

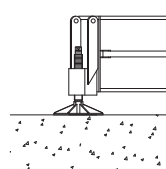

B 2

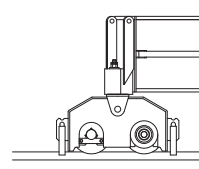

B 3

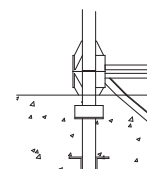

T 4

Dati illustrativi non impegnativi
Con riserva di modifica
senza preavviso

Specifications and data
not binding
Subject to modification without notice

Angaben und Beschreibung
unverbindlich
Änderungen vorbehalten ohne weitere
Mitteilung

Données techniques seulement
indicatives
Modifications réservées sans préavis

CURVE DI CARICO

CARGO CURVES LOAD DIAGRAMS COURBES DE CHARGES

m.	Portata max - Max s.w.l. - Charge maxi																		6,0 t	3,0 t
55	24,28	25	27	29	31	33	35	37	39	41	43	45	47	49	51	53	55	m.		
	3,00	2,90	2,67	2,46	2,29	2,13	2,00	1,88	1,77	1,67	1,59	1,51	1,43	1,37	1,30	1,25	1,20	t		
50					28,32	30	32	34	36	38	40	42	44	46	48	50	m.			
					3,00	2,81	2,62	2,45	2,30	2,17	2,05	1,94	1,84	1,75	1,67	1,60	t			
44						27,68	28	30	32	34	36	38	40	42	44	m.				
						3,00	2,96	2,74	2,56	2,39	2,24	2,11	2,00	1,89	1,80	t				
38							29,81	30	32	34	36	38	m.							
							3,00	2,97	2,77	2,59	2,44	2,30	t							
32								31,02	32	m.										
								3,00	2,90	t										
29									29	m.										
									3,00	t										

m.	Portata max - Max s.w.l. - Charge maxi																		6,0 t	3,0 t				
55	12,7	13	15	17	19	21	23	25	27	29	31	33	35	37	39	41	43	45	47	49	51	53	55	m.
	6,00	5,85	4,98	4,33	3,82	3,41	3,08	2,80	2,57	2,36	2,19	2,03	1,90	1,78	1,67	1,57	1,49	1,41	1,33	1,27	1,20	1,15	1,10	t
50	14,7	16	18	20	22	24	26	28	30	32	34	36	38	40	42	44	46	48	50	m.				
	6,00	5,48	4,81	4,28	3,84	3,49	3,19	2,93	2,71	2,52	2,35	2,20	2,07	1,95	1,84	1,74	1,65	1,57	1,50	t				
44	14,4	16	18	20	22	24	26	28	30	32	34	36	38	40	42	44	m.							
	6,00	5,35	4,69	4,17	3,75	3,40	3,11	2,85	2,64	2,46	2,29	2,14	2,01	1,90	1,79	1,70	t							
38	15,5	16	18	20	22	24	26	28	30	32	34	36	38	m.										
	6,00	5,79	5,08	4,52	4,07	3,69	3,38	3,11	2,87	2,67	2,49	2,34	2,20	t										
32	16,6	18	20	22	24	26	28	30	32	m.														
	6,00	5,49	4,89	4,40	3,99	3,65	3,36	3,11	2,90	t														
29	16,5	17	19	21	23	25	27	29	m.															
	6,00	5,80	5,12	4,58	4,14	3,77	3,46	3,20	t															

TORRE/REAZIONI



MAT RÉACTIONS MASTE/ECKDRÜCKE MAST/REACTIONS MÁSTIL/REACCIONES TRAMO/REACÇÕES





Z (t)	F1 (kN)	H.u.H. (m)	altezza (A=5,9m)	Z (t)	F1 (kN)	H.u.H. (m)	altezza (A=5,9m)	Z (t)	F1 (kN)	H.u.H. (m)	altezza (A=5,9m)				
68,86	761	41,8		70,8	750	41,2		69,3	748	42,2					
51,16	547	35,9	-7	53,1	543	35,3	-7	49,5	542	36,3	-7				
51,16	444	30,0	-6	53,1	444	29,4	-6	49,5	447	30,5	-6				
39,36	390	24,1	-5	41,3	390	23,5	-5	39,6	393	24,6	-5				
39,36	360	18,2	-4	41,3	366	17,6	-4	39,6	369	18,7	-4				
			-3				-3				-3				
			-2				-2				-2				
			-1				-1				-1				
			0				0				0				
Base 3,8x3,8 mt				Base 3,8x3,8 mt				Base 3,8x3,8 mt				Torre 1,2 mt			

F2 (kN)	F3 (kN)	H.u.H. (m)	altezza (A=5,9m)
1411	1625	50,2	
			9
			8
			7
			6
			5
			4
			3
			2
			1
			0
Torre UFC TP 12/15			

MECCANISMI

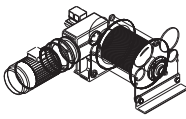
MÈCANISMES ANTRIEBE MECHANISMS MECANISMOS



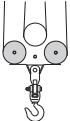









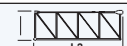









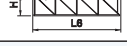

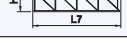

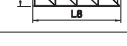

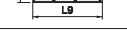

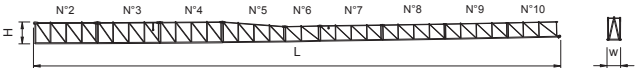

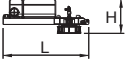

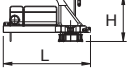

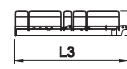
	giri/min	m/min	Nm	Kw
	0,67	-	2 x35	-
	-	15 / 30 / 60	-	4
	-	16	-	2 x 2,2

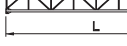
				marcia - step vitesse - gang				
	CV - ch PS - hp	KW			m	m/min	(t)	m/min
18 FV3 30	25	18,4	235	1	0-30	3,0	0-15	6,0
				2	0-47	1,95	0-23,5	3,9
				3	0-60	1,5	0-30	3,0
22 FV3 30	30	22	235	1	0-34	3,0	0-17	6,0
				2	0-50	2,0	0-25	4,0
				3	0-72	1,4	0-36	2,8
30 FV4 30	40	30	460 730* (Lebus)	1	0-45	3,0	0-22,5	6,0
				2	0-57	2,4	0-28,5	4,8
				3	0-77	1,8	0-38,5	3,6
				4	0-94	1,4	0,47	2,8

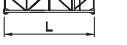
Potenza totale richiesta Total installed power Puissance totale nécessaire Geforderte Stromstärke Potencia necesaria	18 FV3 30 - 43 kVA	400 V - 50 Hz
	22 FV3 30 - 60 kVA	
	30 FV4 30 - 70 kVA	

PESI ED INGOMBRI

PACKING LIST LISTE DE COLISAGE KOLLI-LISTE

Pos. Item	Pezzi Pieces	Denominazione Description	Schizzo Sketch	Dimensioni Dimensions			Peso Weight (Kg)		
				L	W	H	Unit	Total.	
1	1	Elemento di freccia Jib element Elément de flèche Ausleger	N° 1 		6,135	1,280	2,060	*	1410
	1		N° 2 		6,155	1,150	2,060	*	700
	1		N° 3 		6,155	1,150	2,060	*	590
	1		N° 4 		6,155	1,150	2,060	*	490
	1		N° 5 		6,060	1,150	2,030	*	420
	1		N° 6 		3,360	1,150	1,500	*	215
	1		N° 7 		6,060	1,150	1,500	*	340
	1		N° 8 		6,040	1,150	1,500	*	300
	1		N° 9 		6,005	1,150	1,500	*	265
	1		N° 10 		4,785	1,150	1,470	*	220
2	Freccia Flèche Jib Ausleger		55 m 50 m 44 m 38 m 32 m 29 m	49,7 45,0 39,0 33,2 27,3 24,0	1,280 1,280 1,280 1,280 1,280 1,280	2,200 2,200 2,200 2,200 2,200 2,200	*	3540 3320 3055 2755 2415 2200	
3 A	1	Cuspide, A frame, Pointe, Turmspitze.			1,65	1,21	1,73	*	695
3 B	1	Controfreccia girevole, argano di sollev., quadro elettrico Counterjib-turntable, hoisting winch, electrical box etc. Contreflèche tournante, treuil de levage, armoire électrique.			5,085	1,95	2,06	*	5305
3A+3B	1	Gegenausleger, Hubwinde, Drehwerk Schaltschrank.			5,085	1,7	2,65	5850	6000
4	1	Elemento controfreccia esterno External counterjib Contreflèche extérieure Externes gegenausleger			6,715	1,435	1,470	*	1700
5	1	Elemento di torre Tower element Elément de mature Turmstück	(HEM) 		11,8	1,2	1,38	*	3700
6			(HEM) 		5,9	1,2	1,38	*	1960
7			(HEM) 		2,95	1,2	1,38	*	910
8			Tronchetto di fondazione Expendable foundation element Elément a sceller - Fundamentanker (HEM)			1,090	1,38	1,38	*

*(Unit = Total)

Pos Item	Pezzi Pieces	Denominazione Description	Schizzo Sketch	Dimensioni Dimensions (m)			Peso Weight (Kg)		
				L	W	H	Unit	Total.	
9	1	Trave di base principale Base main Beam Poutre de Chassis de base Hauptträger für kreuzgelenk		-	-	-	-	-	
				3,8x3,8mt	5,535	0,710	0,760	* 1460	
10	2	Semi-trave di base Half base beam Semipoutre de chassis de base Hauptträger für kreuzgelenk		-	-	-	-	-	
				3,8x3,8mt	2,620	0,590	0,770	940 1880	
11	2	Bilancino di traslazione folle Driven boige Boggie fou Fahrschemel ohne motorantrieb		1,16	0,25	0,503	455	960	
12	2	Bilancino di traslazione motorizzata Driveng Boige Boggie motorisee Fahrschemel mit motorantrieb		1,16	0,59	0,503	680	1360	
13	24	Blocco di zavorra Base ballast block Lest de base Grundballastblöcken (Z295)		3,600	0,300	1,200	2950	70800	
14	4	Blocco di appoggio Concrete pad Sabot en béton Betonfuss (ZT25)		3,000	0,600	0,600	2465	9860	
15	3	Blocchi di contrappeso Counterweight block Contre-poids Gegengewichtsblöcke		A 125	3,000	0,185	1,200	1250	3750
	4			B 250	3,000	0,370	1,200	2500	10000

*(Unit = Total)



Torre City 1,5 m

Pos Item	Pezzi Pieces	Denominazione Description	Schizzo Sketch	Dimensioni Dimensions (m)			Peso Weight (Kg)	
				L	W	H	Unit	Total.
16	-	Elemento di torre Tower element Elément de mature Turmstück		11,8	1,5	1,7	*	3680
17	-			5,9	1,5	1,7	*	1990
18	-		Tronchetto di fondazione Expendable foundation element élément a sceller Fundamentanker		1,465	1,85	1,85	*
19	1	Trave di base principale Base main beam Poutre de chassis de base		4,5x4,5 m	6,530	0,710	0,760	* 2120
				-	-	-	-	-
20	2	Semi-trave di base Half base beam Semipoutre de chassis de base		4,5x4,5 m	3,200	0,590	0,770	1030 2060
				-	-	-	-	-
21	26	Blocco di zavorra Base ballast block Lest de base Grundballastblöcken (Z295)		3,600	0,300	1,200	2950	76700

*(Unit = Total)

MONTAGGIO

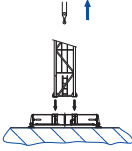
ASSEMBLY MONTAGE VERSAMMLUNG

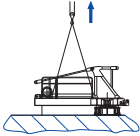
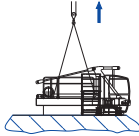
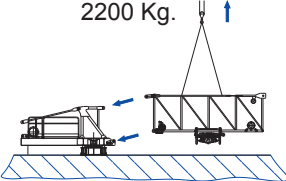
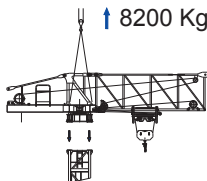
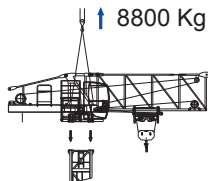
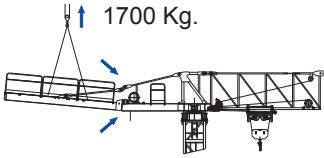
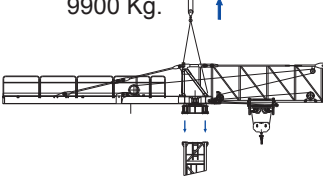
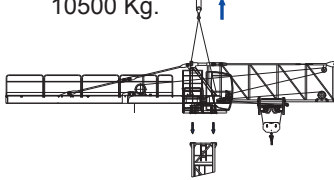
<p>B 3.8x3.8m Tot. 3340 Kg. B 4.5x4.5m Tot. 4180 Kg.</p> 	<p>11.8 / 3050 Kg. 5.9 / 1620 Kg. 2.95 / 810 Kg.</p> 	<p>Z 295 / 2950 Kg.</p> 		
<p>6000 Kg.</p> 	<p>6600 Kg.</p> 	<p>2200 Kg.</p> 	<p>8200 Kg.</p> 	<p>8800 Kg.</p> 
<p>1700 Kg.</p> 	<p>9900 Kg.</p> 	<p>10500 Kg.</p> 		

SOPRALZO IDRAULICO versione HC - 118

EXTERNAL CLIMBING KLETTERRKRANE TELESCOPABLE

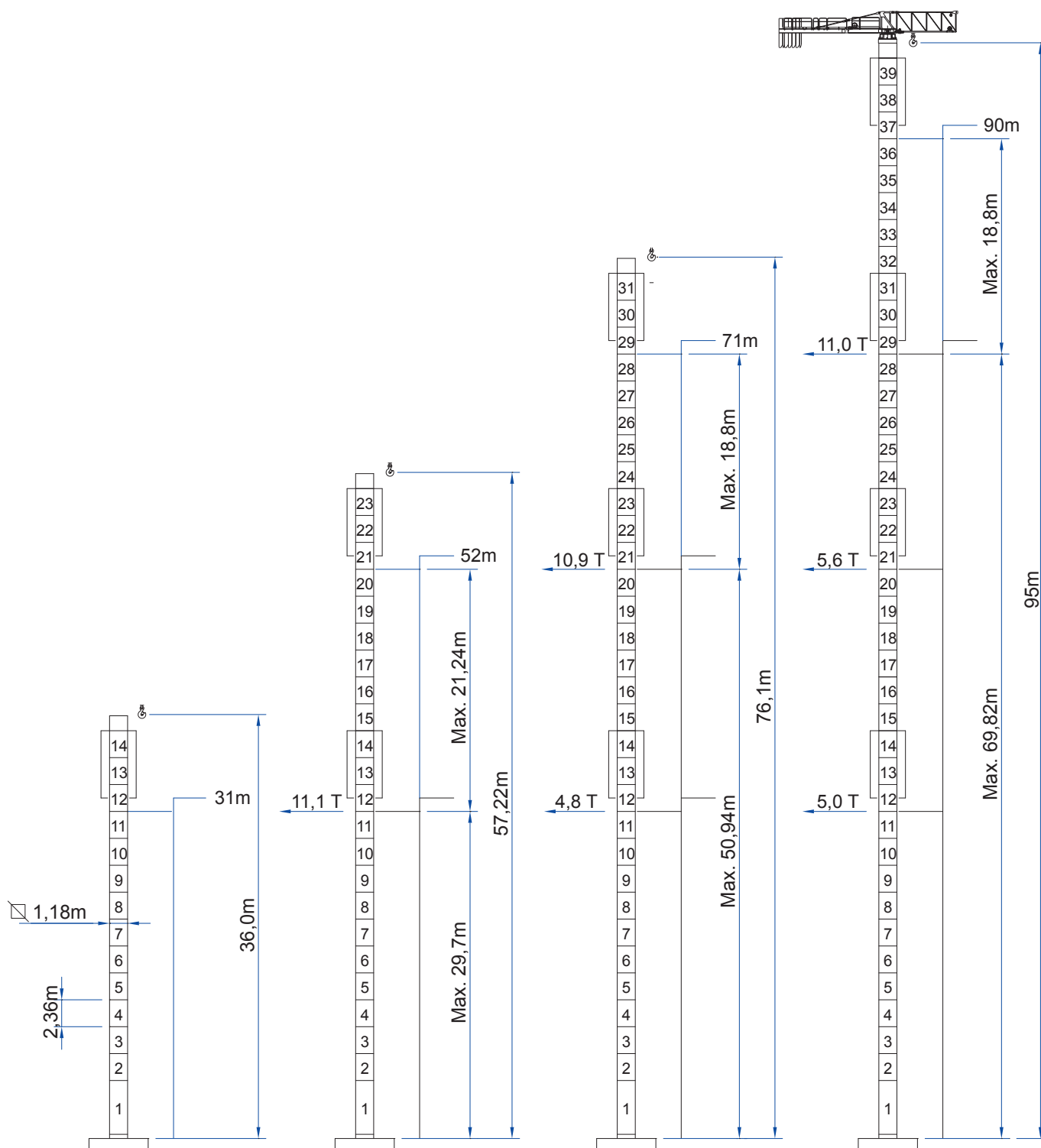

TGM GRU srl

via al Corbé, 15
22076 Mozzate (CO) - Italy
tel. +39 0331 837266
fax +39 0331 833497
info@tgmgru.com
www.tgmgru.com



Rev. "1" (07/08)

comunicate.eu