

B1

STABILIZZATORE REGOLABILE
CON BLOCCO DI APPOGGIO
regolable stabilizator
with concrete pad

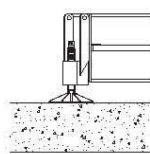

B2

STABILIZZATORE REGOLABILE
regolable stabilizator

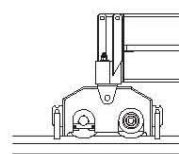

B3

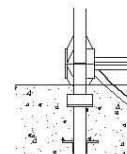

TRASLAZIONE MOTORIZZATA
motorized translation







T4

TRONCHETTO DI FONDAZIONE
expendable foundation element

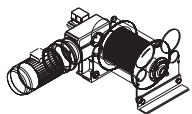

MECCANISMI MECHANISMS ANTRIEBE MÉCANISMES MECANISMOS

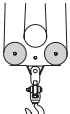
	giri/min	m/min	Nm	Kw
	0,67	-	2x35	-
	-	15/30/60	-	4
	-	15	-	2x2,2





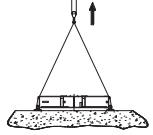
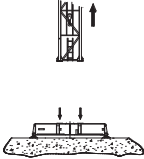

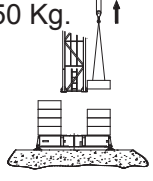
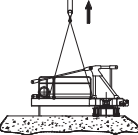
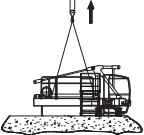
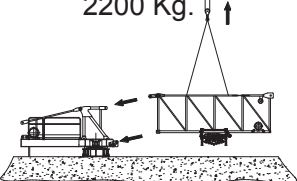
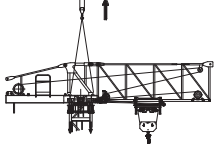
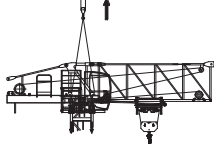
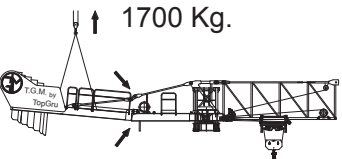
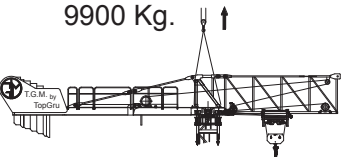
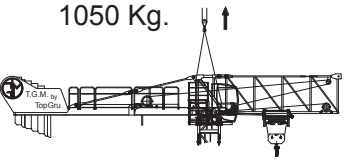

								
	CV - ch PS - hp	KW			m	m/min	(t)	m/min
18 FV3 30 inverter	25	18,4	160 235	1	0-7,5	3,0	0-3,7	6,0
				2	0-30	3,0	0-15	6,0
				3	0-47	1,95	0-23,5	3,9
				4	0-61	1,4	0-30,5	2,8
22 FV3 30 inverter	30	22	160 235	1	0-5	3,0	0-2,5	6,0
				2	0-34	3,0	0-17	6,0
				3	0-50	2,0	0-25	4,0
				4	0-68	1,4	0-34	2,8

Potenza totale richiesta - Total installed power Geforderte Stromstärke - Puissance totale nécessaire Potencia necesaria	18 FV3 30 - 43 kVA 22 FV3 30 - 60 kVA	400 V - 50 Hz
--	--	---------------

MONTAGGIO ASSEMBLY VERSAMMEWNG MONTAGE ASAMBLEA

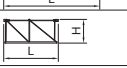
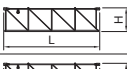
B 3.8x3.8m Tot. 3340 Kg.		11.8 / 3700 Kg. 5.9 / 1960 Kg. 2.95 / 910 Kg.	Z 295 / 2950 Kg.	
				
5850 Kg.	6450 Kg.	2200 Kg.	8050 Kg.	8650 Kg.
				
1700 Kg.		9900 Kg.	1050 Kg.	
				

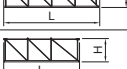
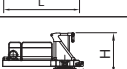
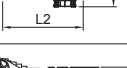
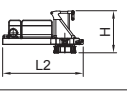
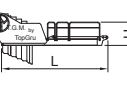
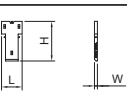
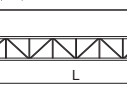
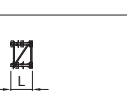
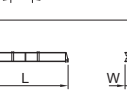
LISTA DEI PESI PACKING LIST KOLLI-LISTE LISTE DE COLLISAGE LISTA DE PESOS

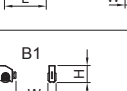
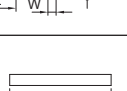
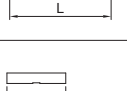
Pos. Item	Pezzi Pieces	Denominazione Description	Schizzo Sketch	Dimensioni Dimensions			Peso Weight (Kg)		
				L	W	H	Unit.	Total.	
1	1	Elemento di freccia Jib element Ausleger Elément de flèche Elemento de flecha	N°10 	6.135	1.280	2.060	1410	1410	
	1		N°11 	6.155	1.150	2.060	700	700	
	1		N°12 	6.155	1.150	2.060	590	590	
	1		N°13 	6.155	1.150	2.060	490	490	
	1		N°14 	6.060	1.150	2.030	420	420	
	1		N°19 	3.360	1.150	1.500	215	215	
	1		N°15 	6.060	1.150	1.500	340	340	
	1		N°16 	6.040	1.150	1.500	300	300	
	1		N°17 	6.005	1.150	1.500	265	265	
	1		N°18 	4.785	1.150	1.470	220	220	
2	1	Gruppo Controfreccia girevole Group Counterjib-turntable Groupe Gegenausleger Groupe Contreflèche tournante Contreflecha giratorio		5.085	1.7	2.65	6000	6000	
3	1	Elemento controfreccia esterno External counterjib Externes Gegenausleger Contreflèche extérieure Elemento de controflecha externo		6.715	1.435	1.470	1700	1700	
4	4	Blocchi di contrappeso Counterweight block Gegengewichtsblöcke Contre-poids Bloques de contrapeso		A960	1.30	0.185	2.50	960	3840
	A2500			1.30	0.47	2.50	2500	10000	
5	-	Elemento di torre (HEM) Tower element (HEM) Turmstück (HEM) Elément de mature (HEM) Elemento de torre (HEM)			11.8	1.2	1.38	3700	3700
6	-				5.9	1.2	1.38	1960	1960
7	-				2.95	1.2	1.38	910	910
8	-			Tronchetto di fondazione Expendable foundation element Fundamentanker Elément a sceller Tronco de fundacion		1.09	1.38	1.38	605
9	1	Trave principale di base Base main beam Hauptträger für Kreuzgelenk Poutre de chassis de base Viga principal de la base		-	-	-	-	-	
				3,8x3,8 m	5,535	0,710	0,760	1460	1460
	2	Semi-trave di base Half base beam Hauptträger für Kreuzgelenk Semipoutre de chassis de base Mediaviga de la base		-	-	-	-	-	
				3,8x3,8 m	2,620	0,590	0,770	940	1880
	2	Bilancino di traslazione folle / motorizzato Driven boige Fahrschemel ohne/mit motorantrieb Boggie fou/motorisee Eslinga de viajes motorizados/loco		B1	1.16	0.25	0.503	455	960
	B2			1.16	0.59	0.503	680	1360	
10	24	Blocco di zavorra Base ballast block Grundballastblöcken Lest de base Brique de lastre	(Z295) 	3.600	1.200	0.300	2950	70800	
11	4	Blocco di appoggio Concrete pad Betonfuss Sabot en béton Brique de apoyo	(ZT 25) 	3.000	0.600	0.600	2465	9860	